



Gopher Eliminator Operator's Manual



For GE-2000 Gopher Eliminator

GOPHER ELIMINATOR GE-2000 OPERATOR'S MANUAL

This manual is applicable to all models of the
Gopher Eliminator Series.

For inquiries call or write to:
Schlagel Manufacturing, Inc.
4154 Buttermilk Road
Torrington, WY 82240

Toll Free: 888-889-1504
Phone: 307-532-4451
Fax: 307-532-8994

E-mail: sales@schlagel.net
Website: www.schlagel.net

GENERAL INFORMATION

The photos and drawings in this manual may differ slightly from your machine due to design changes. The manufacturer reserves the right to change the design of the machine at any time without notifying the customer.

SERIAL NUMBER AND DECAL LOCATION

It is important to have access to your machine's serial number and keep it on record at all times. The serial number decal on the Gopher Eliminator is located on the center of the side body (left side if standing behind the unit). This decal also includes the machine's model number and our patent number. We recommend the serial & model numbers be written in this manual in the spaces below. Should your sticker become damaged and/or unable to read, you can obtain a new one by sending us your machine's model and serial numbers and a return address.

Having your model and serial number ready when ordering replacement parts will help avoid confusion and assure that you get the correct parts.

Serial Number: _____ Model Number: _____



All new Gopher Eliminator machines come with a one year warranty. This warranty covers all non-wear parts (everything except coulters and points) for one year from the date of purchase. Any labor needed for repairs will not be covered unless labor is provided by a Schlager Manufacturing employee or is pre-approved by Schlager Manufacturing. If warranty parts or repairs are needed, please contact Schlager Manufacturing or your local dealer with your Gopher Eliminator serial and model number along with the warranty authorization sheet included at the back of this manual. Warranty parts and repairs will not be authorized for any part that has been misused, abused, or failed because routine maintenance as specified in this manual was not performed.

SAFETY FIRST!



Watch for this symbol throughout this manual. The information that follows this symbol requires your attention and involves your safety!!!

- **Always disengage all drives, lower machine, put tractor in park, and shut off engine before performing any maintenance or repairs on your machine.**

This includes but is not limited to:

- **Lubricating**
 - **Making Adjustments**
 - **Repair Work**
 - **Filling Tanks**
 - **Machine Inspection**
 - **Replacing Parts**
-
- **Keep hands and feet away from any moving parts at all times.**
 - **Never crawl under the machine without the bar stands in place.**
 - **Always wear safety glasses and other protective wear as needed when performing any adjustment or maintenance.**
 - **Always watch overhead for power lines and other structures when raising/folding/unfolding any piece of equipment.**
 - **THINK AHEAD... Before doing any maintenance, preview what needs to be done and think about the best & safest way to do the job.**
 - **If at any time you have questions about the machine, setting the machine, safety issues, repair issues, or any other inquiry, don't hesitate to call us. Our toll free phone number is 1-888-889-1504.**

SPECIAL SAFETY PRECAUTIONS

- The flat coulter on the Gopher Eliminator has very sharp edges. Use extreme caution when around the coulter.
- Before doing any maintenance on or under the machine, set the machine on the ground and lower the bar stands onto solid level ground to prevent it from tipping forward and falling.
- If maintenance requires the machine to be raised, leave the machine attached to the tractor and lower the bar stands and stand extensions onto solid level ground before performing maintenance.
- When removing and adjusting components, be aware of the weight of the components you will be moving.

When the machine is hitching and unhitching, stands need to be lowered and locked.

When the machine is in use, stands need to be completely raised and locked.



GOPHER ELIMINATOR COMMON ASSEMBLIES

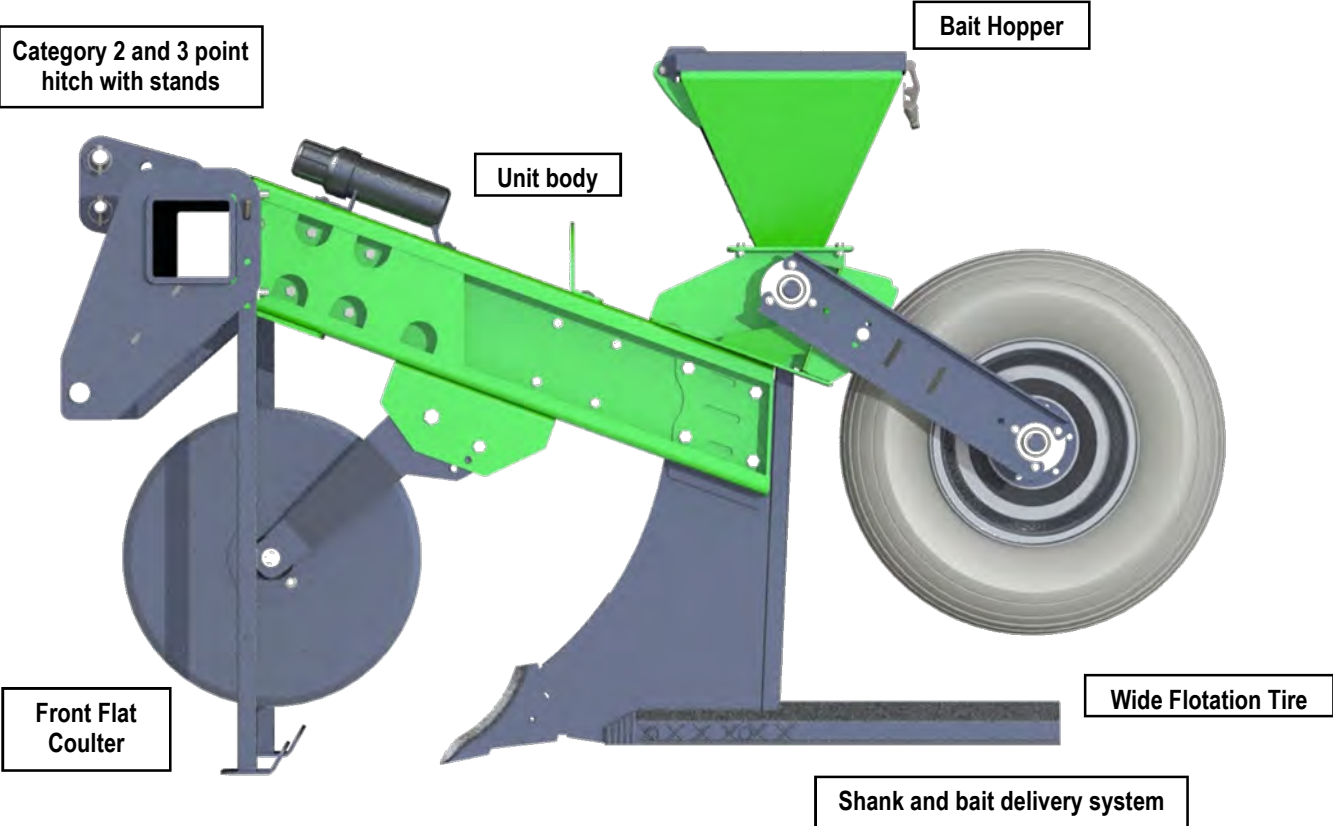

We recommend you take a look through the parts section of this manual for the basic assemblies and parts of the SchlageL Gopher Eliminator before reading the section on adjusting your Gopher Eliminator. Each assembly will have some form of adjustment regarding its particular function.

GE-2000, MAIN BODY

PART NUMBER	DESCRIPTION	QTY.
GE-1002L	LEFT SIDE BODY	1
GE-1002R	RIGHT SIDE BODY	1
GE-1048	GE SIDE BODY SPACER	2
GE-1057	GE-2000 LIFT EYE	1
GE-1063	GE BOLT PLATE	2
HW-1007	3/4"-10 X 9" GR5 ZF HCS	4
HW-1025	1/2"-13 X 3-1/2" GR5 ZF HCS	8
HW-1039	5/8"11 X 4" GR5 ZF HCS	4
HW-1473	5/16"-18 ZF SFN	2
HW-1486	1/2"-13 X 1-1/2" GR5 RH ZF CB	2
HW-1679	3/4" NC NUT, SERRATED FLANGE	4
HW-1828	1/2"-13 ZF SERRATED FN	10
HW-1891	5/8"-11 ZF SERRATED FN	4
HW-1935	5/16" X 0.75 NC CARRIAGE HD BOLT, GR 5	2
HW-2078	OPERATOR'S MANUAL TUBE	1

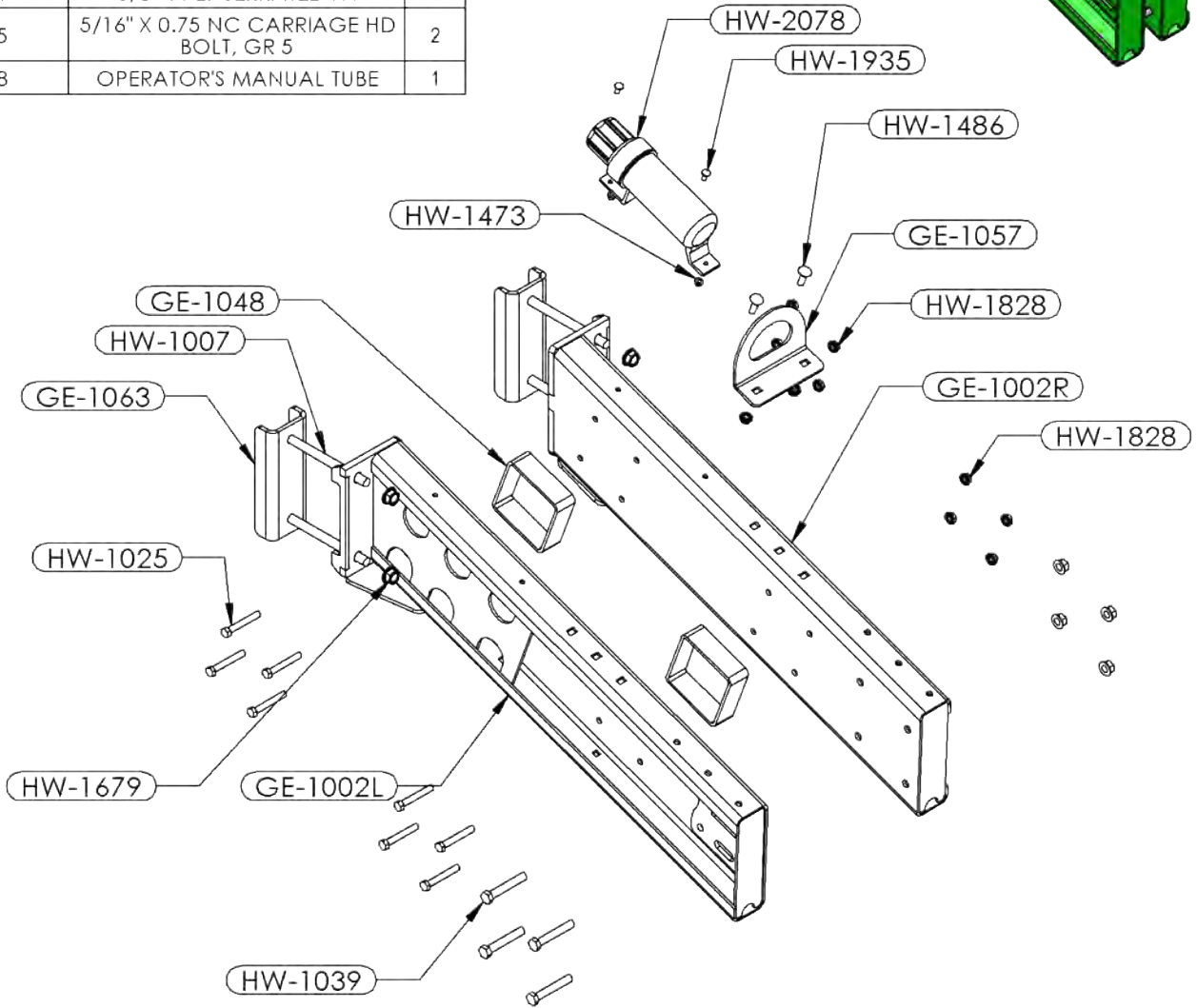
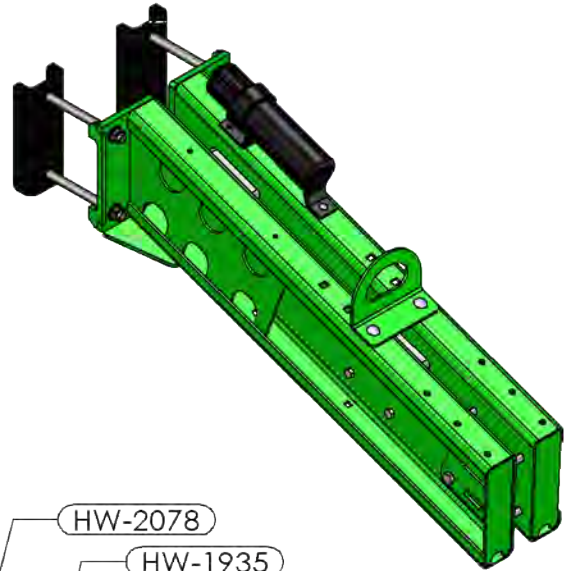

GE-2000, FLAT COULTER

PART NUMBER	DESCRIPTION	QTY.
GE-1035	FC MOUNT BRACKET	1
GE-1040	PA PIVOT BUSHING	1
HW-1093	3/4"-10 X 6-1/2" GR5 ZF HCS	1
HW-1109	1/2"-20 ZF GR5 FHN	4
HW-1127	5/8-11 " X 2" GR5 ZF HCS	2
HW-1177	3/4"-10 X 10" GR5 ZF HCS	1
HW-1251	1/2"-20 X 1-3/4" GR5 ZF HCS	4
HW-1486	1/2"-13 X 1-1/2" GR5 RH ZF CB	4
HW-1679	3/4" NC NUT, SERRATED FLANGE	1
HW-1828	1/2"-13 ZF SERRATED FN	4
HW-1891	5/8"-11 ZF SERRATED FN	2
HW-2345	3/4"-10 GrF ZF FLANGE TOP LN	1
HW-2446	FLAT COULTER, 24" DIA 6.5 MM. 4 BOLT X 5" BOLT CIRCLE	1
TP-2283	BACKING PLATE, FOR FLAT COULTER	1
TP-2943	FLAT COULTER HUB	1
TP-4687	FC & WC EXTERNAL HUB SPACER	2
TP-4967L	FC FORK PLATE (LEFT)	1
TP-4967R	FC FORK PLATE (RIGHT)	1

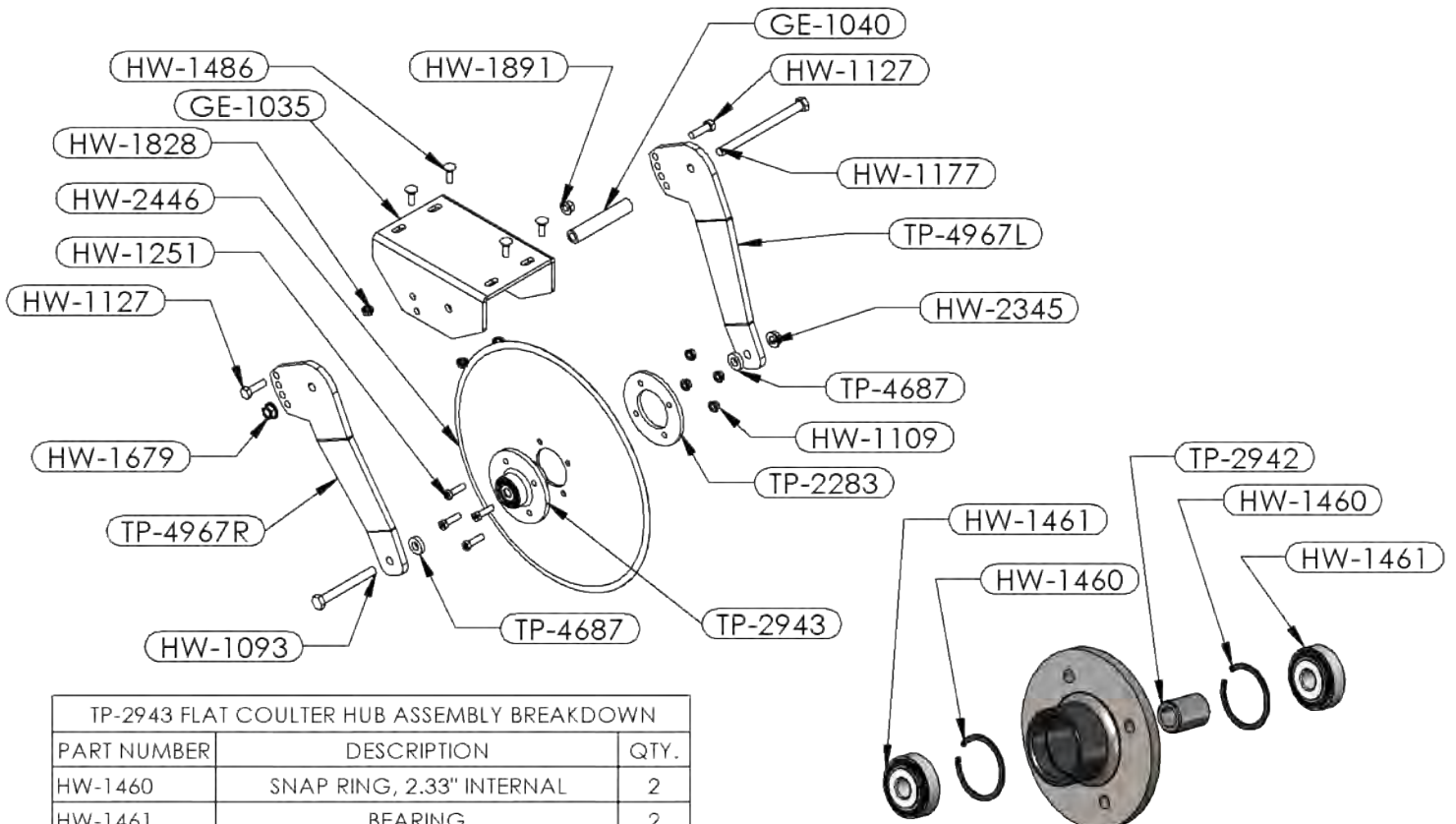

PART NUMBER	DESCRIPTION	QTY.
HW-1460	SNAP RING, 2.33" INTERNAL	2
HW-1461	BEARING	2
TP-2942	SPACER, FLAT COULTER HUB	1

GE-2000, DRIVE WHEEL

PART NUMBER	DESCRIPTION	QTY.
GE-050	AXLE WELDMENT	1
GE-077	KEY STOCK 3/8" X 3/8" X 1.5"	2
GE-078	A2050 CHAIN 57 INCHES	1
GE-1053	SWING ARM	2
GE-1078	IDLER SPACER	6
HW-1152	3/8"-16 X 1" GR5 ZF RH CB	18
HW-1240	1/2"-13 X 2-1/2" GR5 ZF CB	2
HW-1304	A2050 OFFSET HALF LINK	1
HW-1305	A2050 CONNECTOR LK CHAIN LINK	1
HW-1391	3/8"-16 ZF HARDENED SFN	18
HW-1486	1/2"-13 X 1-1/2" GR5 RH ZF CB	8
HW-1828	1/2"-13 ZF SERRATED FN	10
HW-2015	LUG BOLT, 1/2" NF X 1"	6
HW-2105	50B20 SPROCKET 1-7/16" SHAFT	1
HW-2106	50B16 SPROCKET 1-7/16" SHAFT	1
HW-2107	5013 IDLER	2
HW-2170	GOPHER BEARING	6
HW-2409	TIRE/WHEEL FLOTATION	1

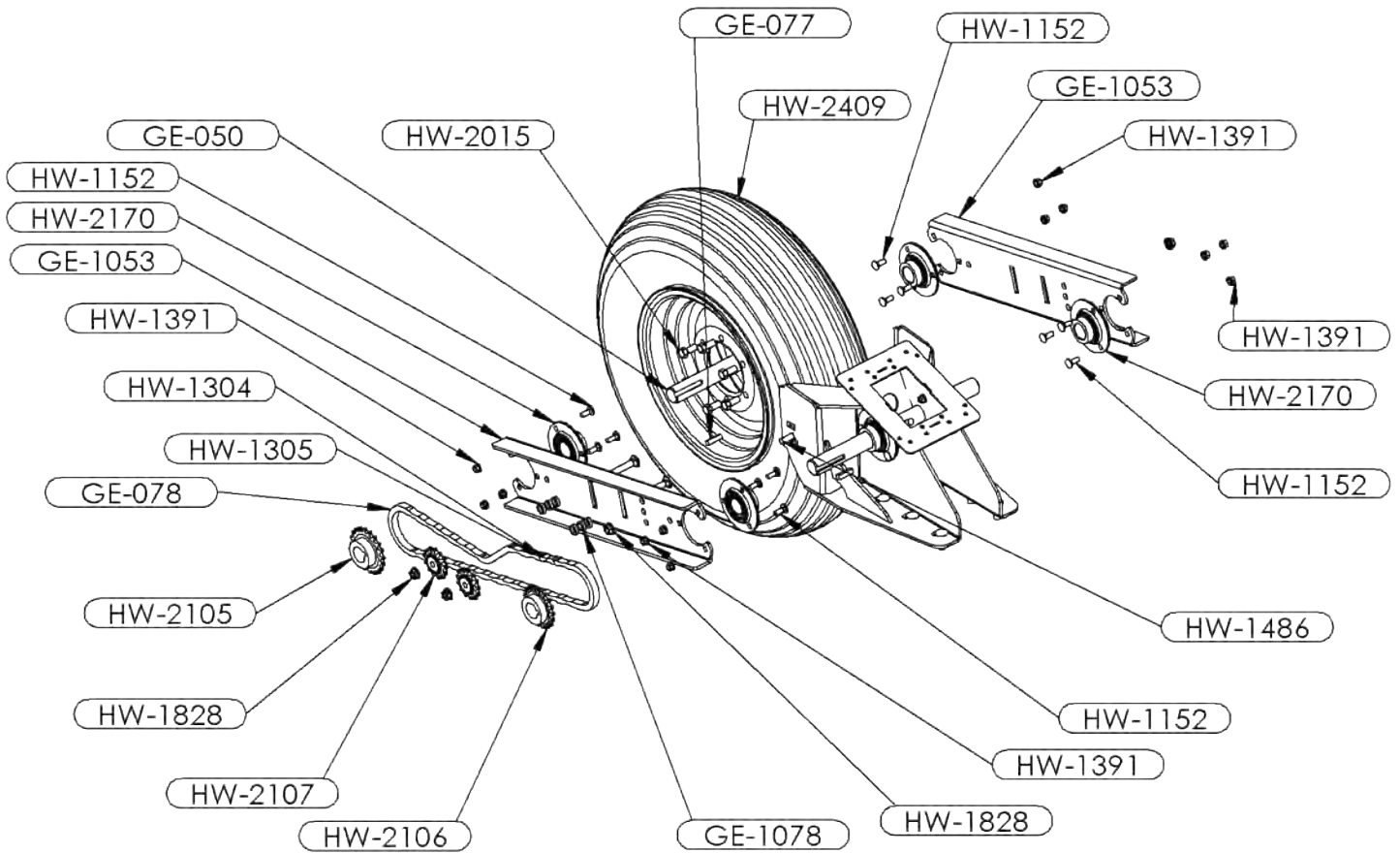

GE-2000, BAIT DISPENSER

PART NUMBER	DESCRIPTION	QTY.
GE-028	BAIT DISPENSING SHAFT	1
GE-053	BAIT TROUGH	1
GE-077	KEY STOCK 3/8" X 3/8" X 1.5"	1
GE-1047L	HIP MOUNT BRACKET (LEFT)	1
GE-1047R	HIP MOUNT BRACKET (RIGHT)	1
GE-1064	BEARING SHIM	2
HW-1152	3/8"-16 X 1" GR5 ZF RH CB	6
HW-1391	3/8"-16 ZF HARDENED SFN	6
HW-1486	1/2"-13 X 1-1/2" GR5 RH ZF CB	6
HW-1828	1/2"-13 ZF SERRATED FN	6
HW-2170	GOPHER BEARING	2
HW-2403	CAP 1.5	1

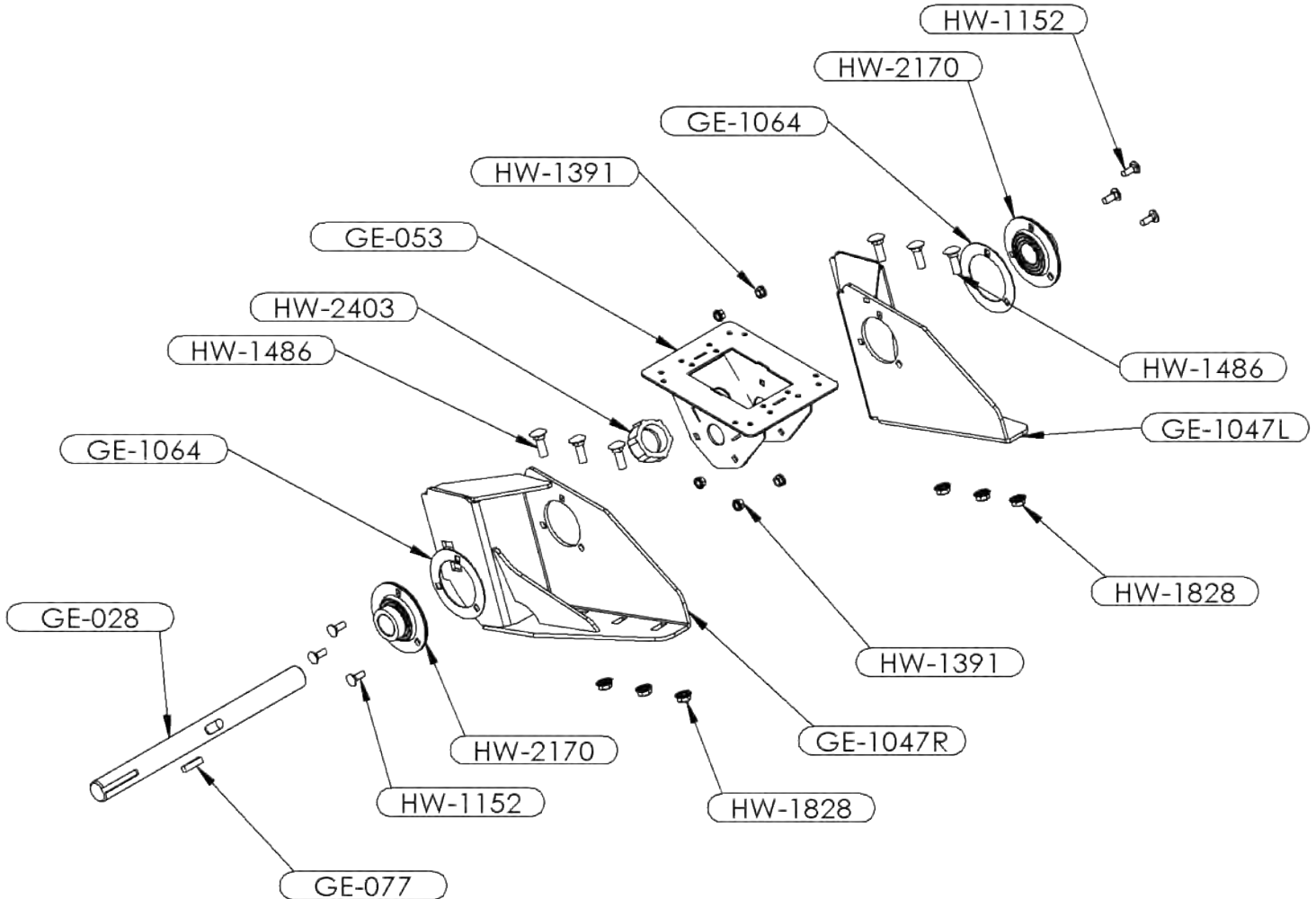

GE-2000, SHANK

PART NUMBER	DESCRIPTION	QTY.
GE-1049	SHANK AND BURROW FORMER ASSY	1
HW-1039	5/8"-11 X 4" GR5 ZF HCS	4
HW-1479	ROLL PIN (SPRING PIN), 5/16" X 1.5", STAINLESS STEEL	1
HW-1891	5/8"-11 ZF SERRATED FN	4
TP-4647N	POINT, 3/4" CAST	1

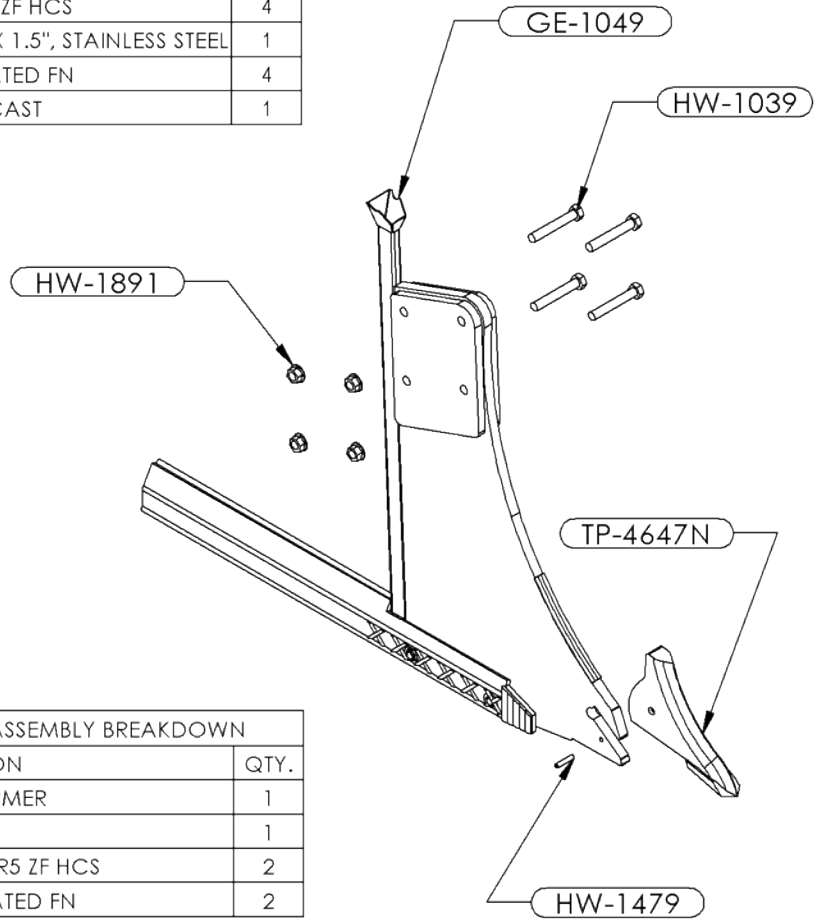

GE-1049 SHANK AND BURROW FORMER ASSEMBLY BREAKDOWN		
PART NUMBER	DESCRIPTION	QTY.
GE-051	BURROW FORMER	1
GE-1050	SHANK	1
HW-1125	1/2"-13 X 2-1/4" GR5 ZF HCS	2
HW-1828	1/2"-13 ZF SERRATED FN	2

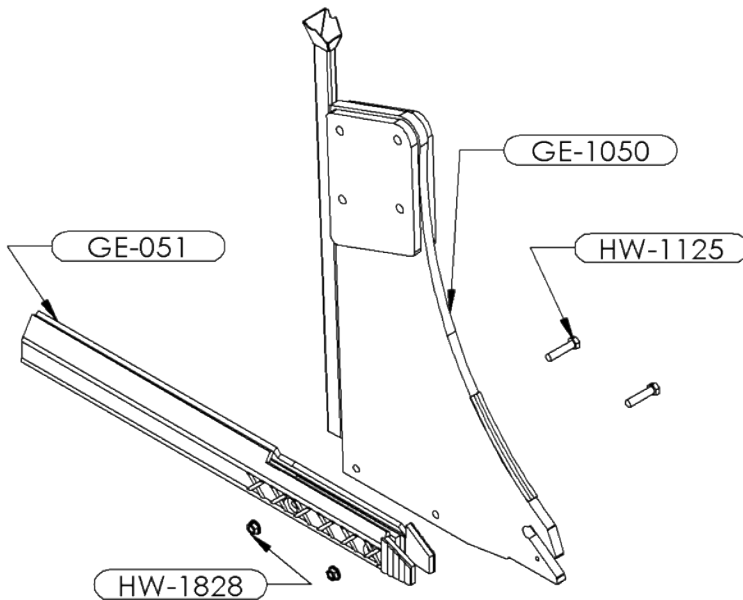

GE-2000, HOPPER

PART NUMBER	DESCRIPTION	QTY.
GE-088	HOPPER LID	1
GE-1010	HOPPER	1
GE-1077	SIGHT GLASS	1
HW-1116	3/8-16 X 1 ZF HCS	2
HW-1151	#8 x 0.438" OD ZF FLAT WASHER	8
HW-1155	3/8"-16 GR2 ZF NYLON INSERT LN	2
HW-1473	5/16"-18 ZF SFN	8
HW-1575	#10-24 x 1/2 PAN HD MACHSCREW	12
HW-2159	5/16" X 1-1/4" HH ZF SFB	8
HW-2246	#10-24 NYLON LOCK NUT	12
HW-2459	RUBBER DRAW LATCH W METAL STRIKE	1

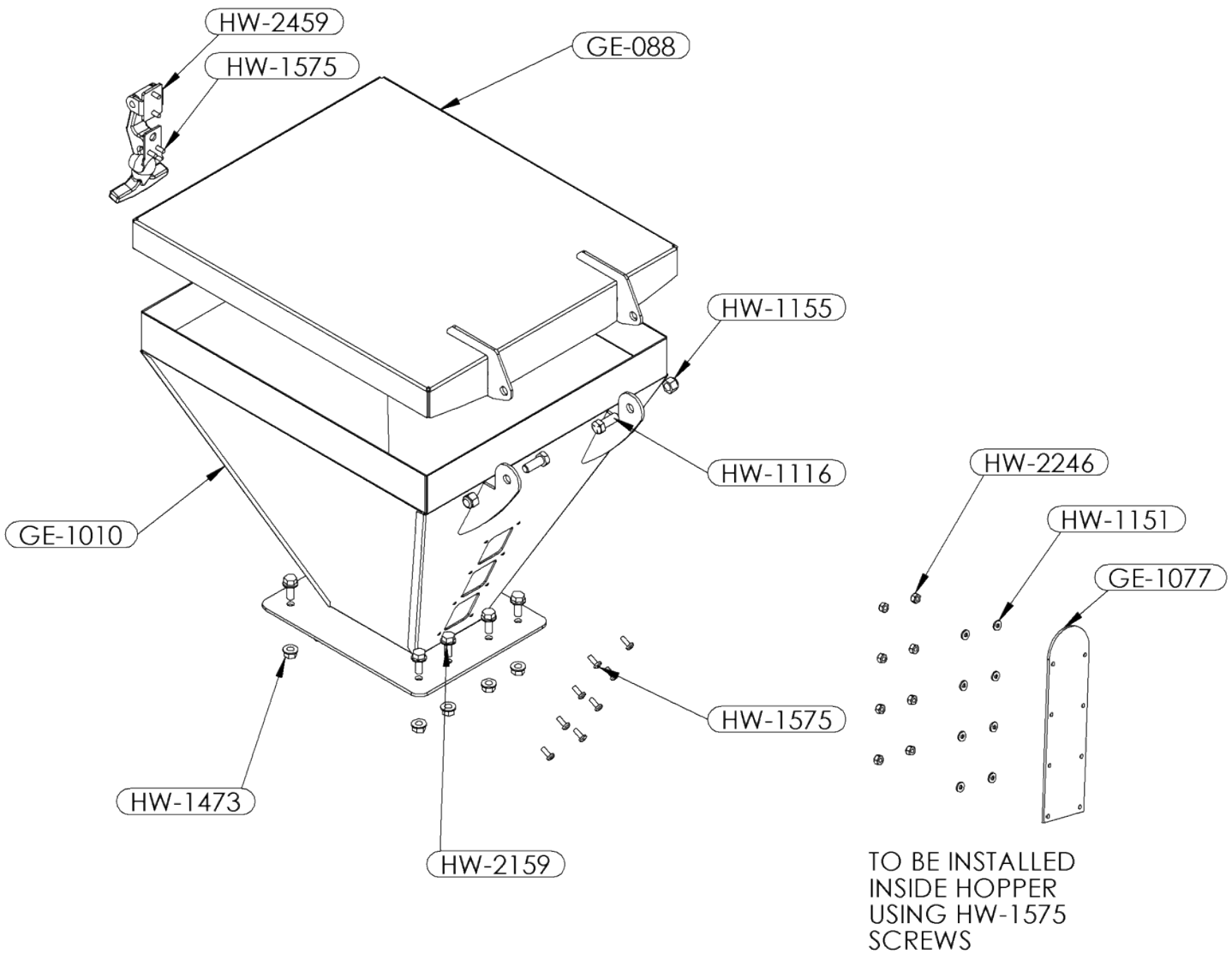

GE-2000, 3 POINT ASSEMBLY

PART NUMBER	DESCRIPTION	QTY.
GE-046	BAR STAND	2
GE-1031	3 POINT	1
HW-1031	7/16" X 2" LYNCH PIN	4
HW-1957	BENT PIN, 1/2" X 3" X 45 DEG.	2
HW-1958	BOWTIE PIN, 0.120" WIRE, 1/2"-5/8" CAP.	2
HW-2514	CAT 2-3 LIFT ARM PIN	2
HW-2515	CAT 2-3 LIFT ARM BUSHING	2
HW-2516	CAT 2 CENTER LINK PIN	1
HW-2517	CAT 3 CENTER LINK PIN	1

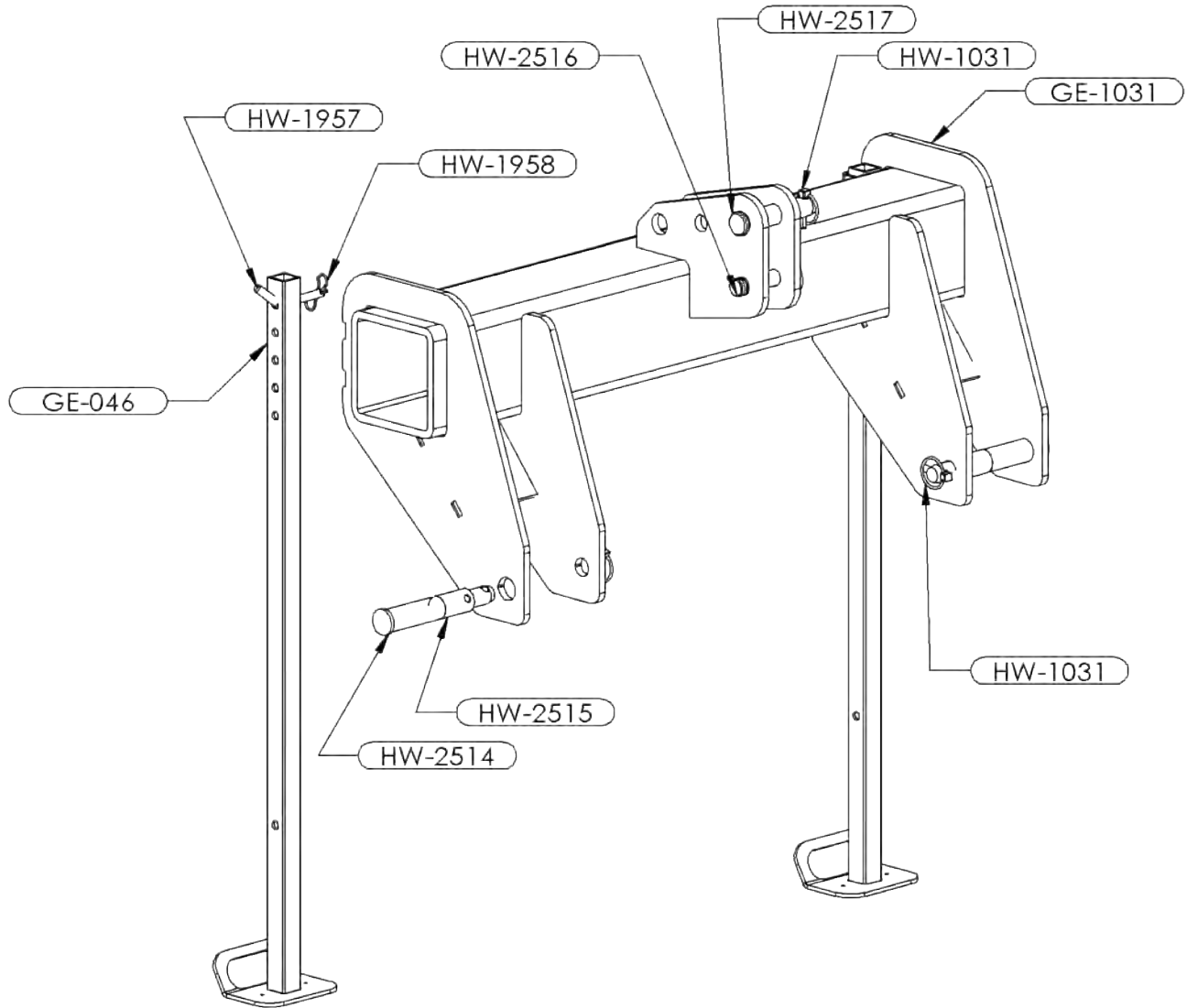
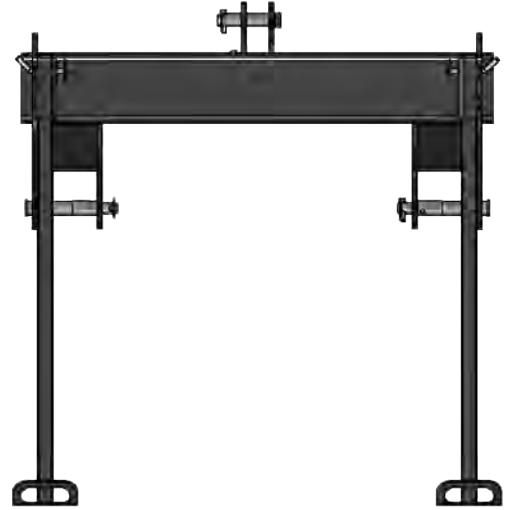

INFORMATION REGARDING GOPHER ELIMINATOR

The Gopher Eliminator is built with larger tractors in mind but will work fine on smaller tractors as well. It has category 2 and 3 three-point hookups, a well built frame, and all the components to withstand the horsepower of larger tractors. The Gopher Eliminator is built with a 24" diameter flat coulter to cut trash and roots. The shank is constructed of 3/4" plate and has a soil-shattering, hard-surfaced point. This replaceable point helps prevent slabbing and bringing up large masses of soil. It will shatter and flow through the ground. The seed delivery system is simple and designed to minimize plugging up. A long forming tunnel makes the bait easily accessible to the vermin. The forming tunnel has also been hard surfaced for maximum durability.

The front flat coulter and the rear gauge/drive tire are adjustable for depth. Machine stands are mounted on each end of the three-point bar. For larger operations, these units can be unbolted from the standard three-point bar and two or more units can be mounted onto longer bars for a multiple-baiting system. See the view below as an example of a double unit setup.

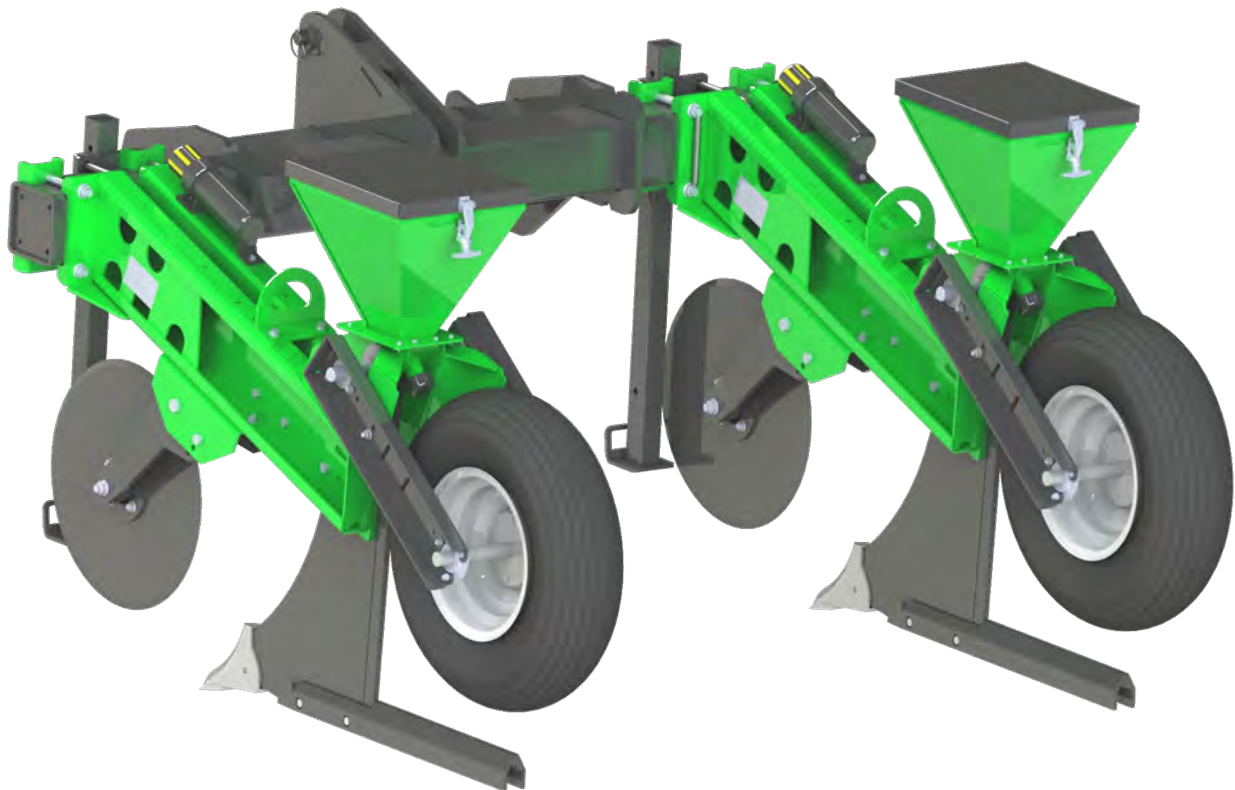

ADJUSTING GOPHER ELIMINATOR

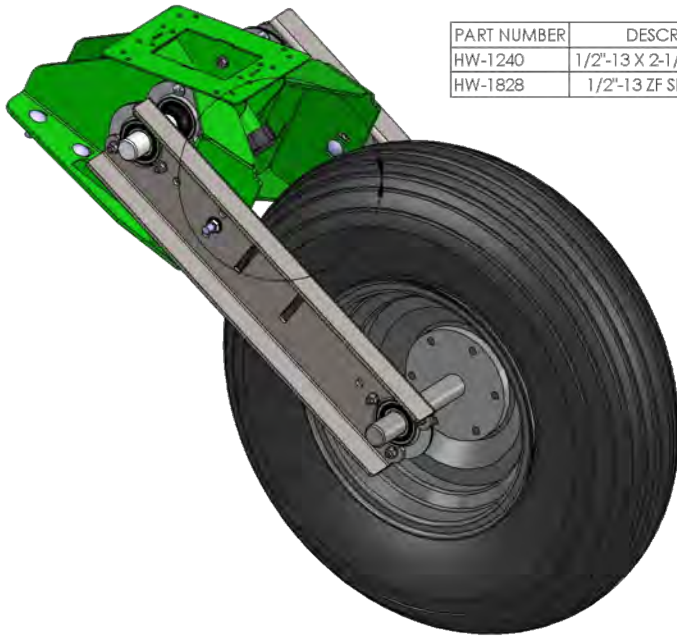

PART NUMBER	DESCRIPTION	QTY.
HW-1240	1/2"-13 X 2-1/2" GR5 ZF CB	2
HW-1828	1/2"-13 ZF SERRATED FN	2

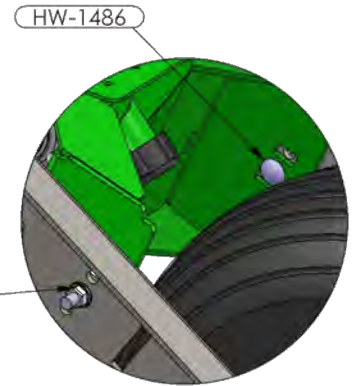

HW-1828

HW-1486

Depth Chart	
Setting	Approximate depth to point (Inches)
Shallow Depth	3-3/8"
Medium Depth	5-1/4"
Maximum Depth	7-1/2"

To adjust the rear drive wheel:

1. Remove nuts and bolts
2. Use the depth chart to determine which setting is appropriate
3. Secure flotation tire in place with nuts and bolts
4. Make sure nuts are locked in place at all times during operation

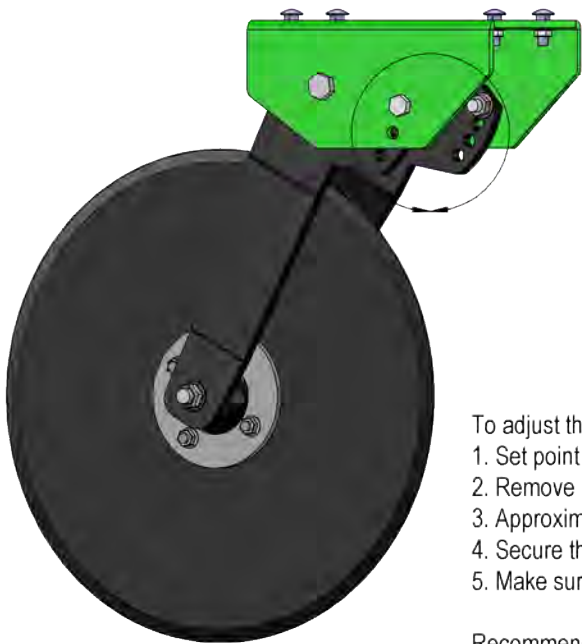

PART NUMBER	DESCRIPTION	QTY.
HW-1127	5/8"-11 " X 2" GR5 ZF HCS	2
HW-1891	5/8"-11 ZF SERRATED FN	2

HW-1127

HW-1891

To adjust the flat coulters depth:

1. Set point depth first
2. Remove nuts and bolts
3. Approximate depth by measuring down from the lowest point on the rear tire
4. Secure the flat coulters in place with nuts and bolts
5. Make sure nuts are locked in place at all times during operation

Recommended depth: 4-5" under surface

TROUBLESHOOTING

PROBLEM	PROBABLE CAUSE	CORRECTION
PLUGGING BETWEEN FLAT COULTER AND SHANK	Flat coulter not deep enough	Lower flat coulter
	Shank not deep enough	Set machine to run deeper
	Machine tilling depth not consistent caused by manually raising and lowering machine in tough areas	Gear down tractor and maintain consistent machine tilling depth
	Flat coulter not aligned with shank	Align flat coulter with shank
	Residue worked too deep into ground and is wet (possibly from disking too deep)	Lower flat coulter
MACHINE NOT PENETRATING INTO SOIL	Flat coulter too deep (holding up unit)	Raise flat coulter
	Shank depth set too shallow	Lower shanks
	Points worn excessively	Replace points
	Tractor 3-point controls not set to allow linkage to be lowered far	Adjust 3-point controls
PLUGGING BAIT TUBE	Unit not level on center link and bait is pooling inside bait tube	Level the unit during operation or very slightly forward

PREPARATION AND STORAGE

PRE-SEASON

- Review safety precautions in this manual.
- If Gopher Eliminator needs a new point, order early to ensure you receive one in time.
- Check the machine over for material defects and cracks, especially near weld joints. If there are any faults, repair or replace parts before operating the machine.
- Check all bearings on the flat coulter and replace if not in good operating condition.
- Check all bolts, nuts, lock washers, flat washers, roll pins, cotter pins, etc. for being worn, loose or cracked. Replace or tighten as needed.

POST-SEASON

- Remove any trash and debris from machine.
- Wash all soil and excess debris that has accumulated on the machine with pressurized water if available.
- Remove all rust and repaint areas where paint has been removed.
- Make list of parts that need replacing for next use and order them early.
- Make any needed repairs and replace any damaged or worn parts.

